

THIS DRAWING AND THE DESIGN IT COVERS ARE THE PROPERTY OF TENGIZCHEVROL. THEY ARE MERELY LOANED AND ON THE BORROWERS EXPRESS AGREEMENT THAT THEY WILL NOT BE REPRODUCED COPIED LOANED EXHIBITED NOR USED EXCEPT IN THE LIMITED WAY AND PRIVATE USE PERMITTED AND WRITTEN CONSENT GIVEN BY TENGIZCHEVROL TO THE BORROWER.

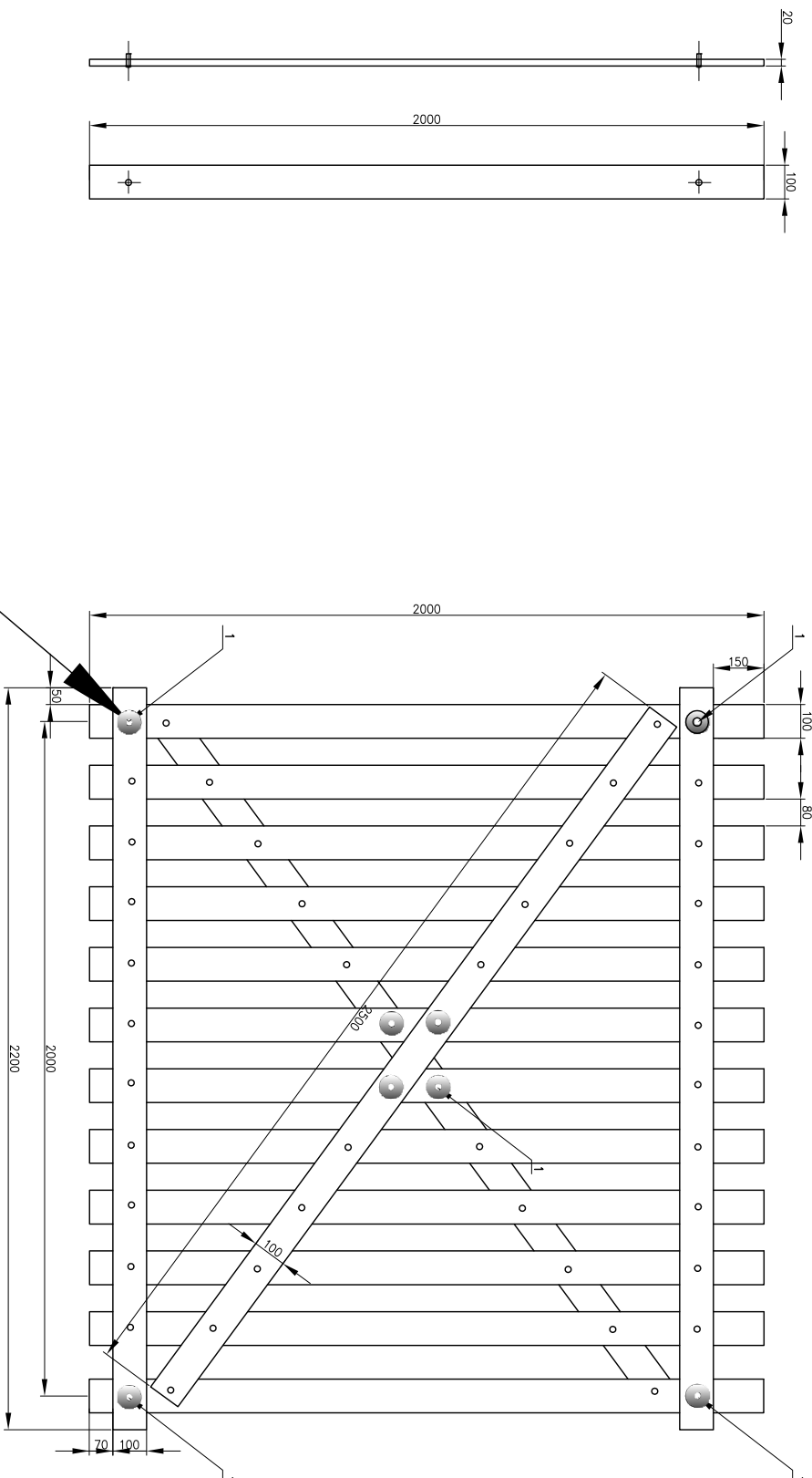

DETAILED VIEW
ДЕТАЛЬНЫЙ ВИД

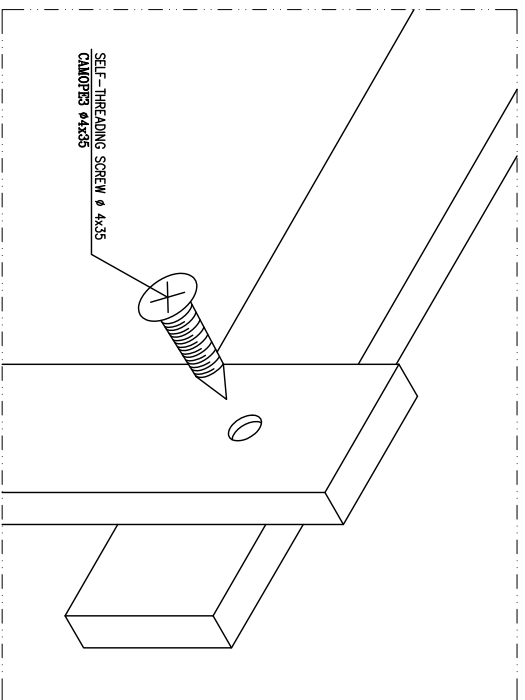
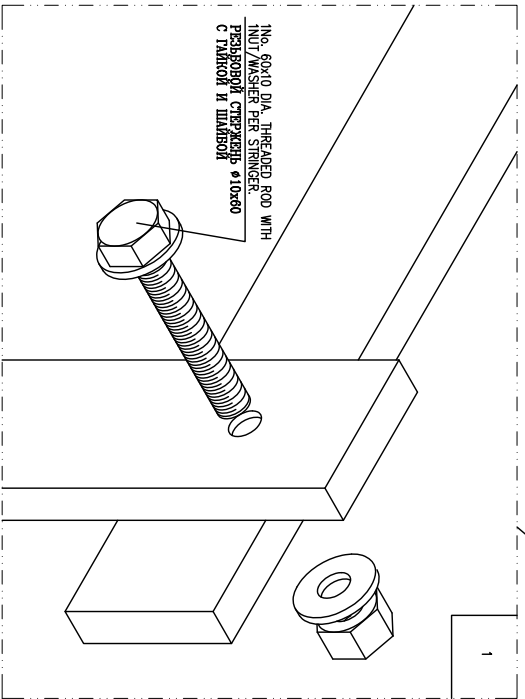

FRONTAL VIEW
ВИД СПЕРЕДИ

BOARD MANNER OF FASTENING
СПОСОБЫ КРЕПЛЕНИЯ ДЮСОВ

NOTES ПРИМЕЧАНИЯ

1. ALL DIMENSIONS ARE IN MILLIMETERS UNLESS OTHERWISE SPECIFIED
ВСЕ РАЗМЕРЫ ДАНЫ В МИЛЛИМЕТРАХ ЕСЛИ НЕ УКАЗАНО ИНАЧЕ
2. FIXING ON THE CORNERS AND IN THE CENTER BOLTS (1)
КРЕПЛЕНИЕ ПО УГЛАМ И В ЦЕНТРЕ ПРОИЗВОДИТСЯ БОЛТАМИ (1)
ВСЕ ОСТАЛОЕ КРЕПЛЕНИЕ САМОПЕРСАМИ

<p>ТЕНГИЗШЕВРОЙЛ TENGIZCHEVROL</p>		<p>TCO RAILROAD GROUP RECOMMENDED INSTALLATION SNOW FENCE</p> <p>ЖЕЛЕЗНОДОРОЖНЫЙ ОУДЕЛ ТИПО РЕКОМЕНДОВАННОЕ УСТРОЙСТВО СНЕГОЗАЩИТНЫЙ ЦИПТ</p>	
<p>DRAMA BY ENGINEER OPERATIONS</p>	<p>CHECKED BY SUPERVISOR PROJ MGR</p>	<p>PROJ No GEO-01-TRR-11</p> <p>DRAWING No TRR-Q-001</p> <p>SCALE NTS</p>	<p>REV DATE</p> <p>ISSUED FOR INFORMATION Выдвучено для информаций</p> <p>REVISION</p> <p>DI UKA ZI BY CHK SIPV MGR ENG OPER</p>

